

JW JOULWATT® JW5522

0.7V Ultra-low Input Voltage, 3.6A Boost Converter with Pass-Through

Preliminary Specifications Subject to Change without Notice

DESCRIPTION

The JW5522 is a synchronous high-efficiency, boost converter with 1.8V input start-up voltage. The device adopts valley current mode control topology. With a wide input voltage range of 0.7V to 5.5V, the JW5522 supports one-cell Li-Ion or Li polymer, or a two to three-cell alkaline Ni-Cd or Ni MH battery or super capacitor backup power applications.

The JW5522 operates at 1.0MHz switching frequency. The device enters power-save mode at light load condition to maintain high efficiency over the entire load current range. JW5522 can disconnect the output from input during the shutdown mode. When input voltage exceeds the regulated output voltage, JW5522 enters pass-through mode automatically.

The JW5522 offers full protection including SCP, OVP and OTP with SOT563.

Company's Logo is Protected, "JW" and "JOULWATT" are Registered Trademarks of Joulwatt technology Co., Ltd.

FEATURES

- 1.8V Minimum Start-up Input Voltage
- 0.7V to 5.5V Input Voltage Range
- 2.2V to 5.5V Output Voltage Range
- Two 47mΩ (LS) / 68mΩ (HS) MOSFET
- 3.6A Valley Switching Current Limit
- 94% Efficiency at $V_{IN}=3.6V$, $V_{OUT}=5V$ and $I_{OUT}=1.5A$
- 1.0MHz Switching Frequency
- Typical 30uA Typical Quiescent Current and 0.1μA Shutdown Current from V_{IN} and SW
- Auto PFM Operation Mode at Light Load
- Pass-Through Mode When $V_{IN} > V_{OUT}$
- True Disconnection Between Input and Output during Shutdown
- Output Over-voltage and Output Short-Circuit Protection
- Package: SOT563

APPLICATIONS

- Electronic Shelf Label
- Video Doorbell
- Remote Controller

TYPICAL APPLICATION

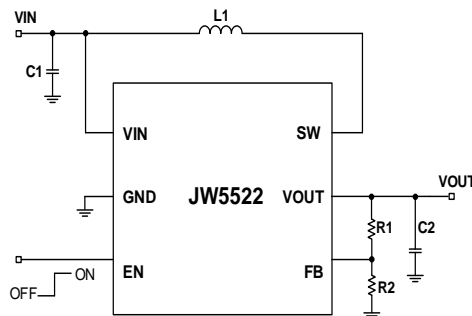

ORDER INFORMATION

DEVICE ¹⁾	PACKAGE	TOP MARKING ²⁾	ENVIRONMENTAL ³⁾
JW5522SOTI#TR	SOT563	JAQ□ YW□□	Green

Notes:

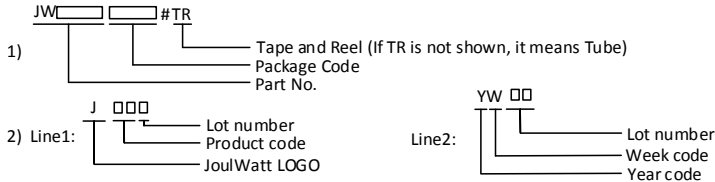

3) All JoulWatt products are packaged with Pb-free and Halogen-free materials and compliant to RoHS standards.

PIN CONFIGURATION

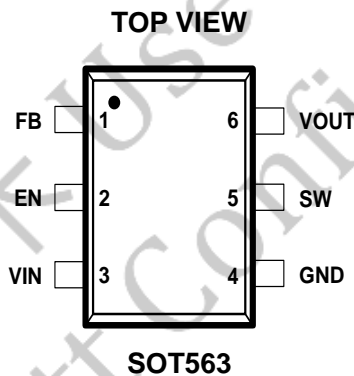

ABSOLUTE MAXIMUM RATING¹⁾

All Pins	-0.3V to 7V
Dynamic LX Voltage in 10ns Duration	-0.7V to 8V
Dynamic LX Voltage in 1ns Duration	-0.7V to 9V
Junction Temperature Range ²⁾	-40°C to +150°C
Power Dissipation, P _D @ (T _A = 25°C) ³⁾	0.74W
Storage Temperature Range	-65°C to +150°C

ESD Ratings

Human-body model (HBM).....	±2000V
Charged-device model (CDM).....	±500V

RECOMMENDED OPERATING CONDITIONS⁴⁾

Input Voltage VIN	0.7V to 5.5V
Operation Junction Temperature (T _J)	-40°C to +125°C

THERMAL PERFORMANCE⁵⁾

θ_{JA} θ_{JC}

SOT563^(TBD)..... 183.240.8 °C/W

Note:

- 1) Exceeding these ratings may damage the device. These stress ratings do not imply function operation of the device at any other conditions beyond those indicated under RECOMMENDED OPERATIONF CONDITIONS
- 2) The JW5522 includes thermal protection that is intended to protect the device in overload conditions. Continuous operation over the specified absolute maximum operating junction temperature may damage the device.
- 3) The maximum allowable continuous power dissipation at any ambient temperature is calculated by $PD (MAX) = (T_J(MAX) - T_A) / \theta_{JA}$.
- 4) The device is not guaranteed to function outside of its operating conditions.
- 5) Measured in the natural convection at $T_A = 25^\circ C$ on a four-layer JoulWatt Evaluation Board

For 小米 Use Only
JoulWatt Confidential

ELECTRICAL CHARACTERISTICS

$T_J = -40^{\circ}\text{C}$ to 85°C and $V_{IN} = 0.9\text{ V}$ to 5.5 V . Typical values are at $V_{IN} = 3.7\text{ V}$, $T_J = 25^{\circ}\text{C}$, unless otherwise noted. *Advance Information, not production data, subject to change without notice.*

Item	Symbol	Condition	Min.	Typ.	Max.	Units
Power Supply						
Input Voltage Range	V_{IN}		0.7		5.5	V
Input Under Voltage Lockout Threshold	V_{UVLO}	V_{IN} rising		1.7	1.8	V
UVLO Hysteresis	V_{UVLO_HYS}			1		V
Quiescent Current into VIN Pin	$I_{Q(VIN)}$	IC enabled, no Load, no Switching, $V_{IN}=1.8\text{V}$ to 5.5V , $V_{FB}=V_{REF}+0.1\text{V}$, $T_J = -40^{\circ}\text{C}$ to 85°C		0.9		μA
Quiescent Current into VOUT Pin	$I_{Q(VOUT)}$	IC enabled, no Load, no Switching, $V_{OUT}=2.2\text{V}$ to 5.5V , $V_{FB}=V_{REF}+0.1\text{V}$, $T_J = -40^{\circ}\text{C}$ to 85°C			30	μA
Shutdown Current into VIN Pin	I_{SD}	IC disabled, $V_{IN} = V_{SW} = 3.6\text{ V}$, $T_J = 25^{\circ}\text{C}$		0.1	0.2	μA
OUTPUT						
Output Voltage Range	V_{OUT}		2.2		5.5	V
Output Over voltage Protection Threshold	V_{OUT_OVP}	V_{OUT} rising		5.8		V
Output Over voltage Protection Hysteresis	$V_{OUT_OVP_HYS}$			0.2		V
Leakage current into VOUT pin	I_{VOUT_LKG}	IC disabled, $V_{IN} = 0\text{ V}$, $V_{SW} = 0\text{ V}$, $V_{OUT} = 5.5\text{ V}$, $T_J = 25^{\circ}\text{C}$			3	μA
Feedback reference voltage	V_{REF}	$V_{IN} < V_{OUT}$	594	600	606	mV
Leakage current into FB pin	I_{FB_LKG}	$V_{FB}=1.0\text{V}$		10	50	nA
Soft startup time	t_{SS}	From active EN to VOUT regulation. $V_{IN} = 2.5\text{ V}$, $V_{OUT} = 5.0\text{ V}$, $C_{OUT} = 10\mu\text{F}$, $I_{OUT} = 0$		700		μs
POWER SWITCH						
High Side PMOS On Resistance	$R_{DS(ON)_HS}$	$V_{OUT}=5.0\text{V}$		68		m Ω
Low Side NMOS On Resistance	$R_{DS(ON)_LS}$	$V_{OUT}=5.0\text{V}$		47		m Ω
Switching Frequency	F_{SW}	$V_{IN} = 3.6\text{ V}$, $V_{OUT} = 5.0\text{ V}$		1		MHz
Minimum on time	t_{ON_MIN}			80		ns
Minimum off time	t_{OFF_MIN}			80		ns
Switching valley current limit	I_{LIM_SW}	$V_{IN} = 3.6\text{ V}$, $V_{OUT} = 5.0\text{ V}$		3.6		A
Pre-charge current	I_{LIM_CHG}	$V_{IN} = 1.8 - 5.5\text{ V}$, $V_{OUT} < 0.4\text{ V}$		300		mA

		$V_{IN} = 2.4\text{ V}, V_{OUT} = 2.15\text{ V}$		1.2		A
Leakage Current into SW pin(from SW pin to GND)	I_{SW_LKG}	$V_{SW}=5.0\text{ V}$, no Switch, $T_J=-40^\circ\text{C}$ to 85°C			200	nA
Control Logic						
EN logic low threshold	V_{EN_L}	$V_{IN} > 1.8\text{ V}$ or $V_{OUT} > 2.2\text{ V}$			0.4	V
EN logic high threshold	V_{EN_H}	$V_{IN} > 1.8\text{ V}$ or $V_{OUT} > 2.2\text{ V}$	1.2			V
Thermal Shutdown Threshold ⁶⁾	T_{SD}			150		$^\circ\text{C}$
Thermal Recovery Threshold ⁶⁾	T_{REC}			130		$^\circ\text{C}$

Notes:

6) Guaranteed by design.

For 小米 Use Only
JoulWatt Confidential

PIN DESCRIPTION

Name		Description
1	FB	Voltage feedback of adjustable output voltage.
2	EN	Enable logic input. Logic high voltage enables the device. Logic low voltage disables the device and turns it into shutdown mode.
3	VIN	IC power supply input.
4	GND	Ground pin of the IC.
5	SW	The switch pin of the converter. It is connected to the drain of the internal low-side power MOSFET and the source of the internal high-side power MOSFET.
6	VOUT	Boost converter output.

BLOCK DIAGRAM

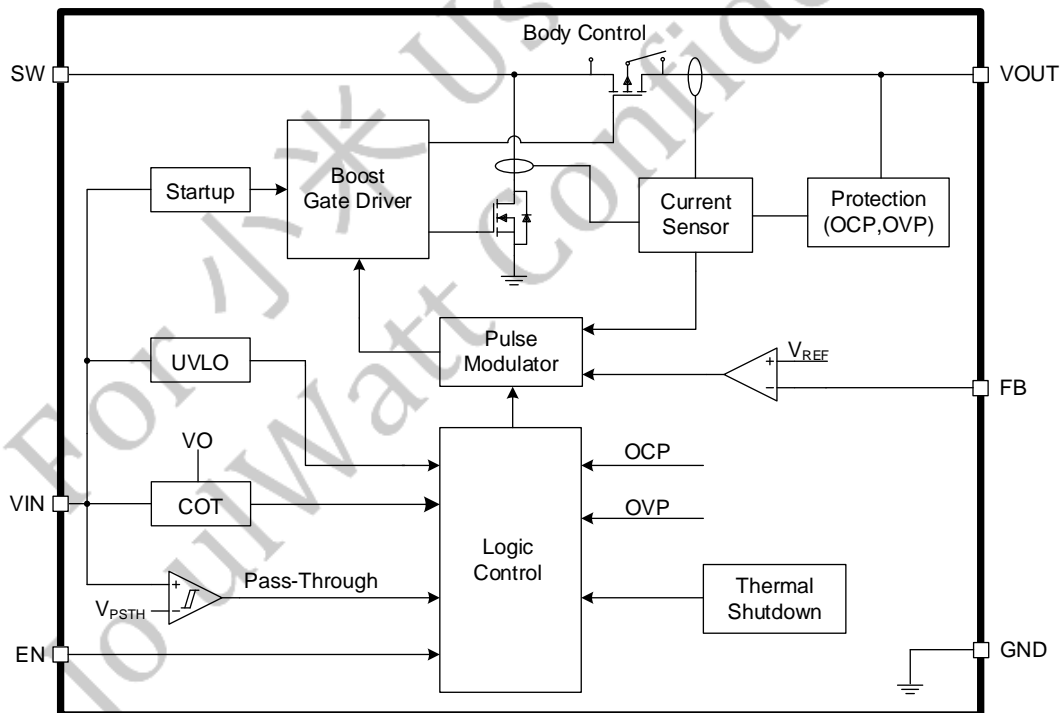

FUNCTIONAL DESCRIPTION

The JW5522 synchronous step-up converter is designed to operate from an input voltage supply range between 0.7 V and 5.5 V with 3.6A (typical) valley switch current limit. The JW5522 typically operates at a quasi-constant frequency pulse width modulation (PWM) at moderate to heavy load currents. The switching frequency is 1MHz/2.5MHz.

PFM is engaged to maintain high efficiency at light load. In PFM mode, switching frequency is continuously controlled in proportion to the load current. Switch frequency decreases when load current drops to increase power efficiency at light load by reducing switching loss and minimizing the circuit power dissipation.

Internal loop compensation simplifies the design process while minimizing the number of external components.

The JW5522 guarantees robustness with short-circuit protection and thermal shutdown.

Start-Up

When the device is enabled, the JW5522 can start up from a voltage as low as 1.8V.

At the beginning, the JW5522 charges the output capacitors with a current of about 300mA when the output voltage is below 0.4V. Once the output voltage is above 0.4V, the output current is changed to having output current capability to drive the 2Ω resistance load.

As the output voltage reaches the higher voltage, the converter enters normal boost mode, in which the JW5522 steps up the voltage to the setting value by following an internal ramp up reference voltage.

Device Enable

The JW5522 starts operation when EN pin is

pulled high and starts up with a soft-start process. Pulling EN pin low can force the device into shutdown mode with a current consumption of typically 0.1μA. In shutdown mode, the chip stops switching and all the internal control circuit is off, and the load is truly disconnected from the input.

Output Disconnection

A true output disconnection between input and output is implemented in the device. This feature guarantees robustness with short-circuit protection to prevent the device from being damaged by inrush current. It can also limit the output current at start-up.

Output Voltage

The output voltage is set by an external feedback resistive divider. The feedback signal is compared with internal precision 0.6V voltage reference by an error amplifier. The output voltage can be given by the equation:

$$V_o(V) = \frac{0.6V \times (R_1 + R_2)}{R_2}$$

Where R_1 and R_2 are defined in the typical application figure.

Switching Frequency

The JW5522 typically operates at a quasi-constant frequency pulse width modulation (PWM) at moderate to heavy load currents. The switching frequency is 1.0MHz.

Current Limit Operation

The JW5522 uses a valley current limit sensing scheme. Current limit detection occurs during the off-time by sensing of the voltage drop across the synchronous rectifier.

When the load current is increased such that

the inductor current is above the current limit within the whole switching cycle time, the off-time is increased to allow the inductor current to decrease to this threshold before the next on-time begins. When the current limit is reached, the output voltage decreases during further load increase.

Pass-Through Operation

The JW5522 supports automatic pass-through function for the boost converter. When the input voltage is higher than the setting output target voltage, the boost converter enters into pass-through operation mode, in which the boost converter stops switching and the PFET is constantly turned on and the NFET is turned off.

In this mode, the output voltage can be derived by the following expression:

$$V_o = V_{in} - I_o \times (R_L + R_{DSON_HS})$$

Where R_L is the DCR of external inductor and R_{DSON_HS} is the resistance of internal high side PFET.

When the output voltage drops below the 95% of the setting target voltage as the input voltage declines or the load current increases, the JW5522 resumes switching again to regulate the output voltage.

Protection

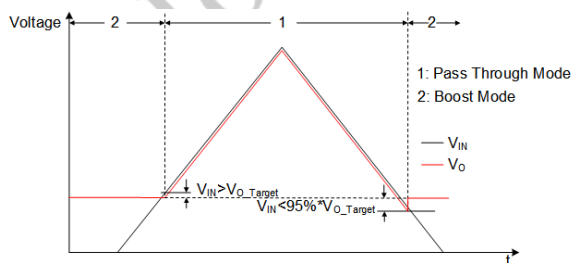

Over Voltage Protection

The JW5522 has an output overvoltage protection (OVP) to protect the device if the external feedback resistor divider is wrongly populated. When the output voltage is above 5.8 V typically, the device stops switching. Once the output voltage is lower than 5.6V, the device resumes operating again.

Output Short Circuit Protection

The JW5522 starts to limit the output current when the output voltage is below 1.8V. The lower the output voltage reaches, the smaller the output current is. When the VOUT pin is short to ground, and the output voltage becomes less than 0.4V, the output current is limited to approximately 300mA. Once the short circuit is released, the JW5522 goes through the soft start-up again to the regulated output voltage.

Thermal Shutdown

When the junction temperature of the device rises above T_{SD} (typ.150°C), the device is forced into shut down mode. When the temperature drops below T_{REC} (typ.130°C), the device can be resumed with soft start.

TAPE AND REEL INFORMATION

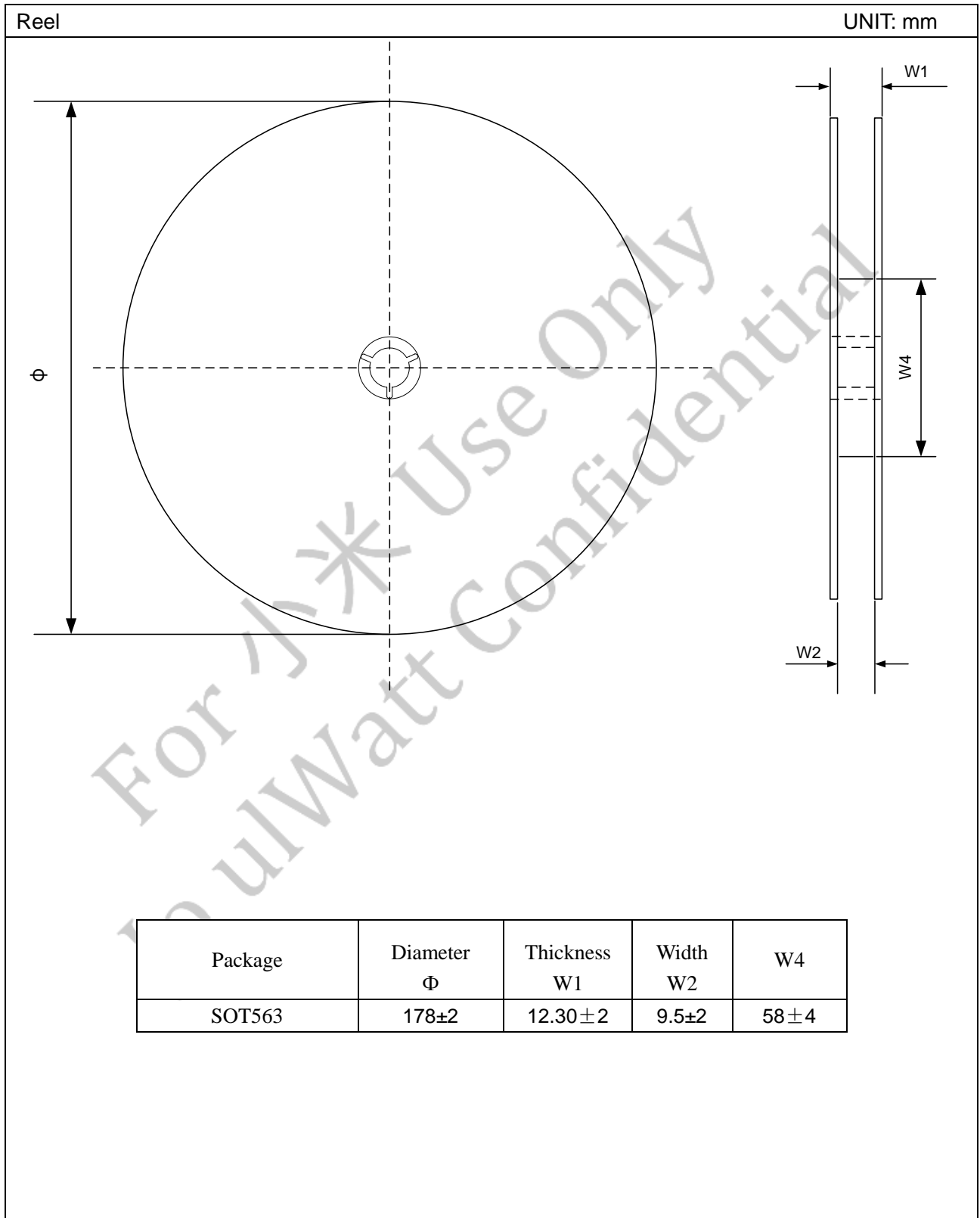

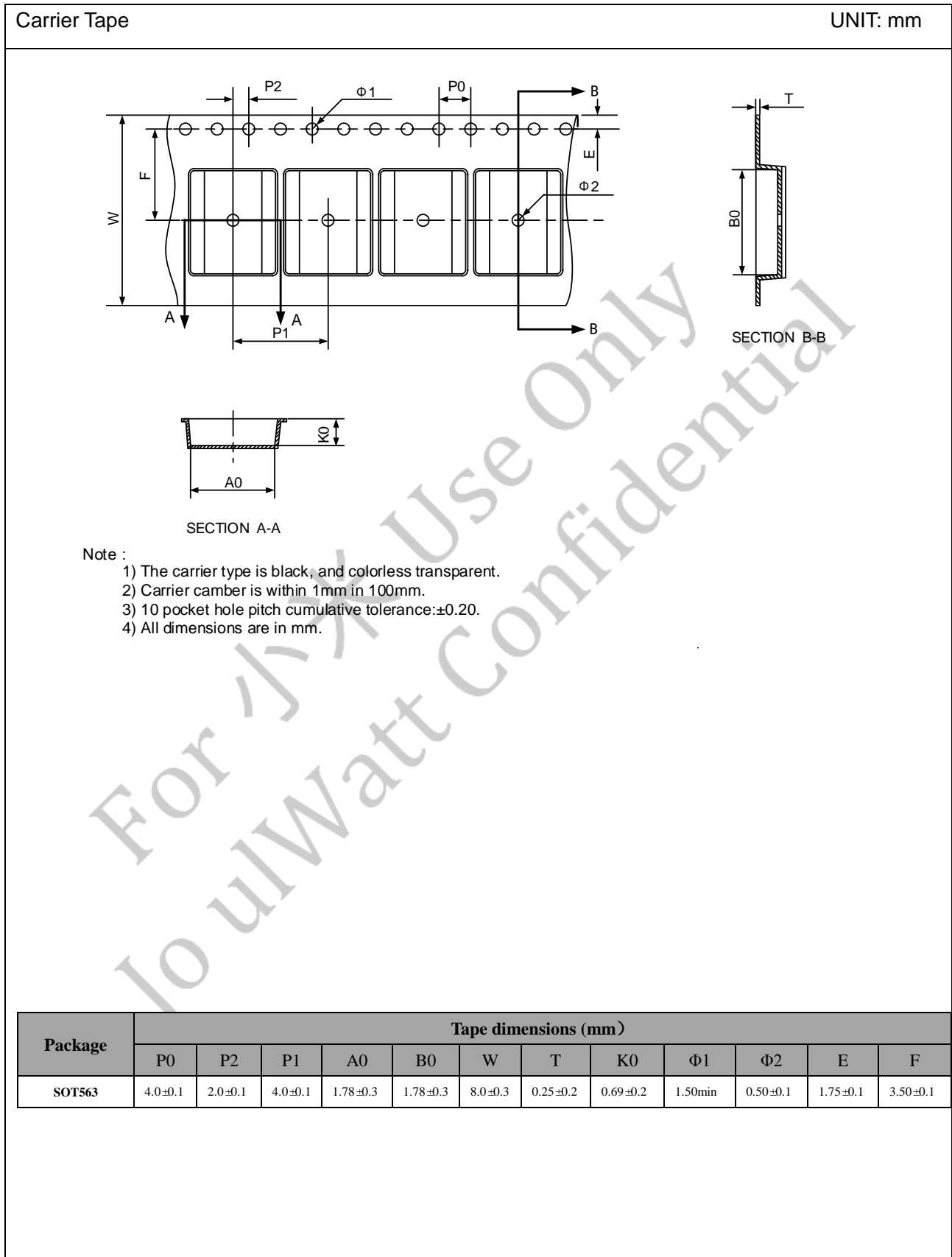

PACKAGE OUTLINE

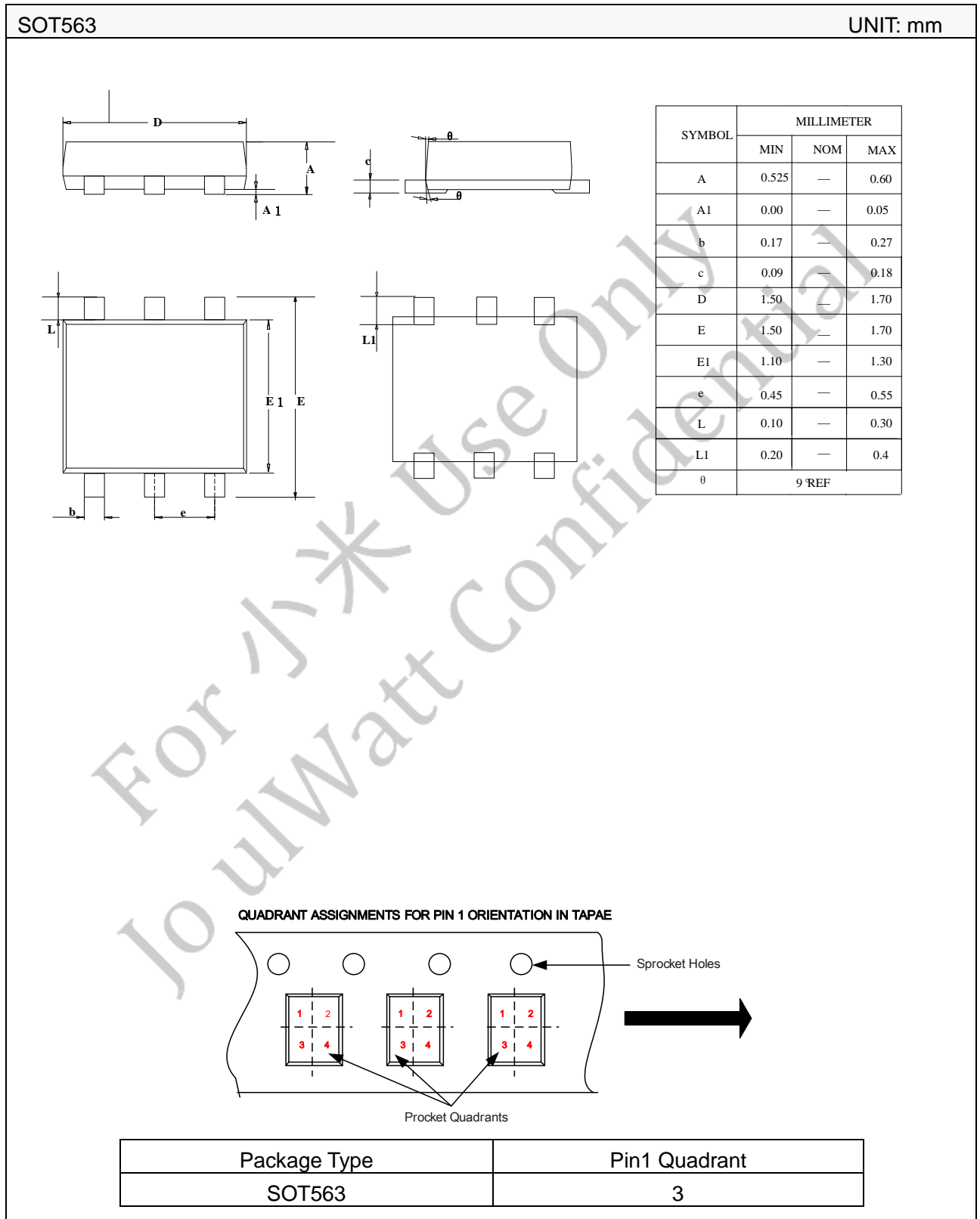

IMPORTANT NOTICE

- Joulwatt Technology Co.,Ltd reserves the right to make modifications, enhancements, improvements, corrections or other changes without further notice to this document and any product described herein.
- Any unauthorized redistribution or copy of this document for any purpose is strictly forbidden.
- Joulwatt Technology Co.,Ltd does not warrant or accept any liability whatsoever in respect of any products purchased through unauthorized sales channel.
- JOULWATT TECHNOLOGY CO.,LTD PROVIDES TECHNICAL AND RELIABILITY DATA (INCLUDING DATASHEETS), DESIGN RESOURCES (INCLUDING REFERENCE DESIGNS), APPLICATION OR OTHER DESIGN ADVICE, SAFETY INFORMATION AND OTHER RESOURCES, AND DISCLAIMS ALL WARRANTIES, EXPRESS AND IMPLIED, INCLUDING WITHOUT LIMITATION ANY IMPLIED WARRANTIES OF MERCHANTABILITY, FITNESS FOR A PARTICULAR PURPOSE OR NON-INFRINGEMENT OF THIRD PARTY INTELLECTUAL PROPERTY RIGHTS.

Copyright © 2022 JoulWatt

All rights are reserved by Joulwatt Technology Co.,Ltd