

## DESCRIPTION

The JW7809 is a low noise low-dropout (LDO) voltage regulator with enable function that operates from 2.2V to 6V. It provides up to 500mA of output current. The feature of low noise and high PSRR makes this device ideal for RF and analog systems.

JW7809 supports output voltage from 1.2V to 4.5V in 25mV steps.

JW7809 guarantees robustness with output short-circuit protection, input under voltage lockout protection and over temperature protection.

JW7809 is available in SOT23-5, X2DFN1\*1-4 and EWDFN2\*2-6 packages.

Company's Logo is Protected, "JW" and "JOULWATT" are Registered Trademarks of Joulwatt Technology Co.,Ltd.

## FEATURES

- Input Voltage Range: 2.2V to 6V
- Output Voltage Range: 1.2V to 4.5V
- Output Current: 500mA
- Output Voltage Accuracy:  $\pm 2.5\%$
- Low  $I_Q$ (Enabled): 11 $\mu$ A
- PSRR: 82dB @1kHz
- Low Output Voltage Noise: 12 $\mu$ V<sub>RMS</sub>
- Stable with 1 $\mu$ F Effective Output Capacitance
- Remote Output Capacitor Placement
- No Noise Bypass Capacitor Required
- Current Limit Protection
- Over Temperature Protection
- Available in SOT23-5, X2DFN1\*1-4, EWDFN2\*2-6 Packages

## APPLICATIONS

- ADAS Cameras and Radar
- ADAS Domain Controller
- Cockpit Domain Controller
- Telematics System

TYPICAL APPLICATION

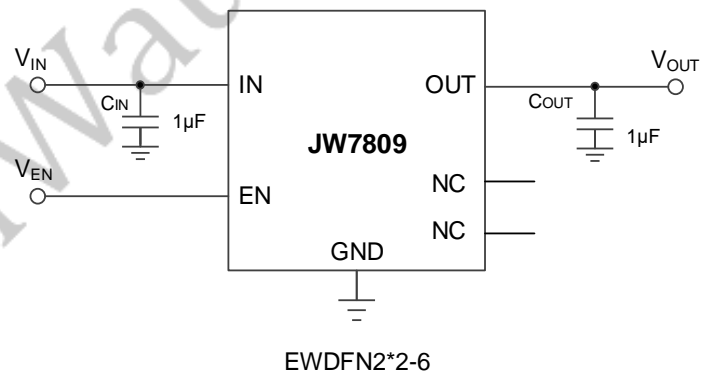
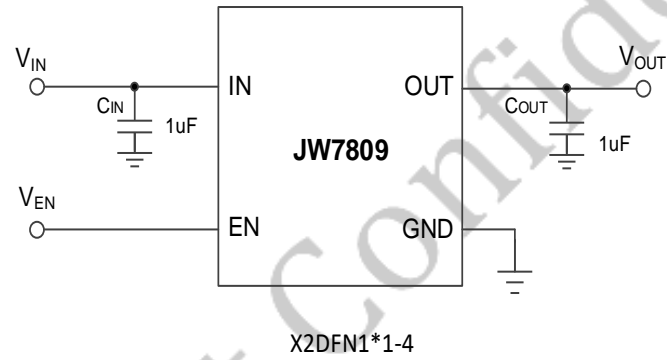
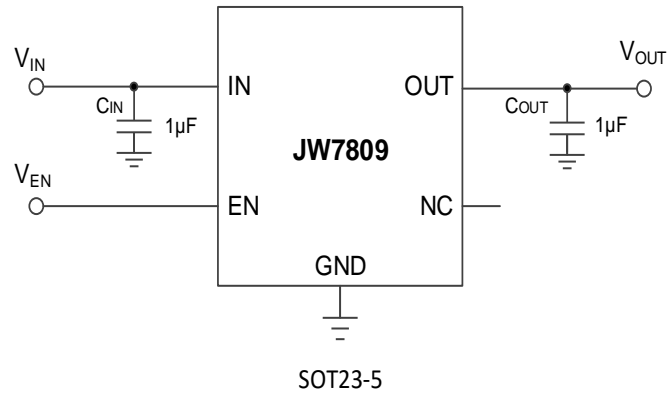

**ORDER INFORMATION**

DEVICE <sup>1)</sup>	PACKAGE	TOP MARKING <sup>2)</sup>	ENVIRONMENTAL <sup>3)</sup>
JW7809-1.2SOTA#TR	SOT23-5	JADA□ YW□□□	Green
JW7809-1.5SOTA#TR	SOT23-5	JADB□ YW□□□	Green
JW7809-1.8SOTA#TR	SOT23-5	JADC□ YW□□□	Green
JW7809-2.5SOTA#TR	SOT23-5	JADD□ YW□□□	Green
JW7809-2.8SOTA#TR	SOT23-5	JADE□ YW□□□	Green
JW7809-2.85SOTA#TR	SOT23-5	JADF□ YW□□□	Green
JW7809-2.9SOTA#TR	SOT23-5	JADG□ YW□□□	Green
JW7809-3.0SOTA#TR	SOT23-5	JADH□ YW□□□	Green
JW7809-3.1SOTA#TR	SOT23-5	JADJ□ YW□□□	Green
JW7809-3.2SOTA#TR	SOT23-5	JADK□ YW□□□	Green
JW7809-3.3SOTA#TR	SOT23-5	JADL□ YW□□□	Green
JW7809-4.0SOTA#TR	SOT23-5	JADM□ YW□□□	Green
JW7809-4.5SOTA#TR	SOT23-5	JADN□ YW□□□	Green
JW7809-1.2X2DHAB#TR	X2DFN1*1-4	4□	Green
JW7809-1.5X2DHAB#TR	X2DFN1*1-4	5□	Green
JW7809-1.8X2DHAB#TR	X2DFN1*1-4	6□	Green
JW7809-2.5X2DHAB#TR	X2DFN1*1-4	7□	Green

JW7809-2.8X2DHAB#TR	X2DFN1*1-4	8□	Green
JW7809-2.85X2DHAB#TR	X2DFN1*1-4	9□	Green
JW7809-2.9X2DHAB#TR	X2DFN1*1-4	A□	Green
JW7809-3.0X2DHAB#TR	X2DFN1*1-4	B□	Green
JW7809-3.1X2DHAB#TR	X2DFN1*1-4	C□	Green
JW7809-3.2X2DHAB#TR	X2DFN1*1-4	D□	Green
JW7809-3.3X2DHAB#TR	X2DFN1*1-4	E□	Green
JW7809-4.0X2DHAB#TR	X2DFN1*1-4	F□	Green
JW7809-4.5X2DHAB#TR	X2DFN1*1-4	G□	Green
JW7809-1.2EWDGBB#TR	EWDFN2*2-6	JADA□ YW□□□	Green
JW7809-1.5EWDGBB#TR	EWDFN2*2-6	JADB□ YW□□□	Green
JW7809-1.8EWDGBB#TR	EWDFN2*2-6	JADC□ YW□□□	Green
JW7809-2.5EWDGBB#TR	EWDFN2*2-6	JADD□ YW□□□	Green
JW7809-2.8EWDGBB#TR	EWDFN2*2-6	JADE□ YW□□□	Green
JW7809-2.85EWDGBB#TR	EWDFN2*2-6	JADF□ YW□□□	Green
JW7809-2.9EWDGBB#TR	EWDFN2*2-6	JADG□ YW□□□	Green
JW7809-3.0EWDGBB#TR	EWDFN2*2-6	JADH□ YW□□□	Green
JW7809-3.1EWDGBB#TR	EWDFN2*2-6	JADJ□ YW□□□	Green
JW7809-3.2EWDGBB#TR	EWDFN2*2-6	JADK□ YW□□□	Green

JW7809-3.3EWDGGB#TR	EWDFN2*2-6	JADL□ YW□□□	Green
JW7809-4.0EWDGGB#TR	EWDFN2*2-6	JADM□ YW□□□	Green
JW7809-4.5EWDGGB#TR	EWDFN2*2-6	JADN□ YW□□□	Green

**Notes :**

- JW□□#TR

  - Tape and Reel (If TR is not shown, it means Tube)
  - Package Code
  - Part No.
- SOT23-5 Line1: JW□□□

  - Product code
  - JoulWatt LOGO

EWDFN2\*2-6

X2DFN1\*1-4 Line1: □□

  - Lot number
  - Product code

Line2: YW□□□

  - Lot number
  - Week code
  - Year code
- All JoulWatt products are packaged with Pb-free and Halogen-free materials and compliant to RoHS standards.

**PIN CONFIGURATION**

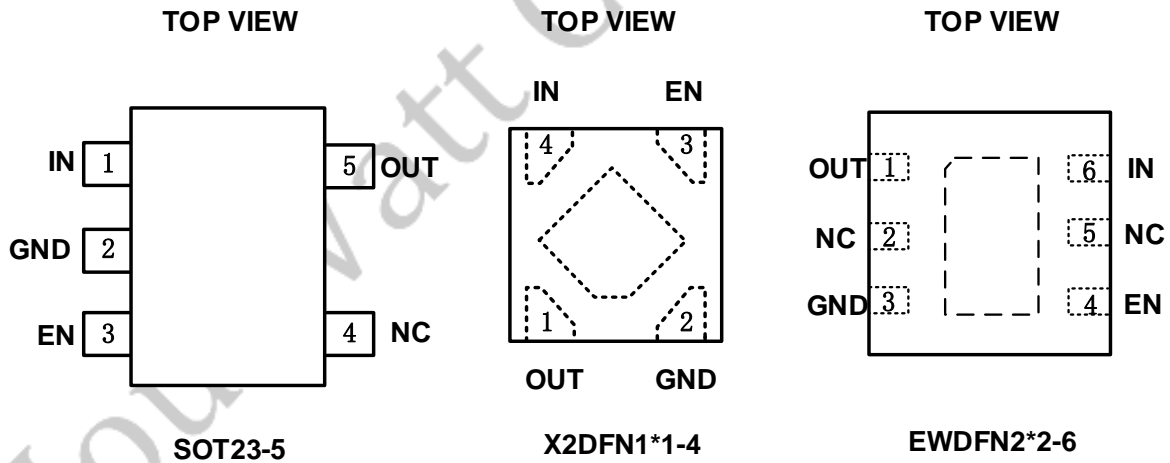

**ABSOLUTE MAXIMUM RATING<sup>1)</sup>**

IN, EN Pin .....	-0.3V to 7V
OUT Pin.....	-0.3V to $V_{IN}+0.3V^{2)}$
Junction Temperature <sup>3)</sup> .....	150°C
Lead Temperature .....	260°C
Storage Temperature .....	-65 °C to 150°C
ESD Susceptibility (Human Body Model).....	±2kV
ESD Susceptibility (Charged Device Model).....	±1kV
MSL (SOT23-5) .....	MSL1
MSL (X2DFN1*1-4) .....	MSL1
MSL (EWDFN2*2-6) .....	MSL1
Continuous Power Dissipation( $T_A=+25^{\circ}C$ ) SOT23-5 .....	0.78W
Continuous Power Dissipation( $T_A=+25^{\circ}C$ ) X2DFN1*1-4 .....	0.61W
Continuous Power Dissipation( $T_A=+25^{\circ}C$ ) EWDFN2*2-6 .....	1.4W

**RECOMMENDED OPERATING CONDITIONS<sup>4)</sup>**

Input Voltage $V_{IN}$ .....	2.2V to 6V
Output Current $I_{OUT}$ .....	0mA to 500mA
Junction Temperature Range .....	-40°C to 125°C

**THERMAL PERFORMANCE<sup>5)</sup>**

	SOT23-5	X2DFN1*1-4	EWDFN2*2-6
$R_{\theta JA}$ Junction-to-ambient thermal resistance.....	128	163.9	70.8 °C/W
$\Psi_{JT}$ Junction-to-top characterization parameter.....	25.8	54.3	21.2 °C/W
$\Psi_{JB}$ Junction-to-board characterization parameter.....	59.7	113.4	44.1 °C/W
$R_{\theta JC(top)}$ Junction-to-case(top) thermal resistance.....	63	207.7	136.6 °C/W
$R_{\theta JC(bot)}$ Junction-to-case(bottom) thermal resistance.....	NA	96.9	26.1 °C/W
$R_{\theta JB}$ Junction-to-board thermal resistance.....	59.9	116	44.6 °C/W

**Notes:**

- 1) Exceeding these ratings may damage the device. These stress ratings do not imply function operation of the device at other conditions beyond those indicated under RECOMMENDED OPERATING CONDITIONS.
- 2) The absolute maximum rating is  $V_{IN}+0.3V$  or 7V, whichever is smaller.
- 3) The JW7809 includes thermal protection that is intended to protect the device in overload conditions. Continuous operation over the specified absolute maximum operating junction temperature may damage the device.
- 4) The device is not guaranteed to function outside of its operating conditions.
- 5) Measured on JESD51-7, 4-layer PCB

**ELECTRICAL CHARACTERISTICS**

$V_{IN}=V_{OUT(NOM)}+1V$ ,  $V_{EN}=1.2V$ ,  $I_{OUT}=1mA$ ,  $C_{IN}=1\mu F$ ,  $C_{OUT}=1\mu F$ ,  $T_J=-40^{\circ}C$  to  $125^{\circ}C$ , unless otherwise stated.

ITEM	SYMBOL	CONDITIONS	MIN.	TYP.	MAX.	UNIT
Input Voltage	$V_{IN}$	$T_A=25^{\circ}C$	2.2		6	V
Input Supply UVLO	$V_{UVLO}$	$V_{IN}$ rising		2	2.19	V
Input Supply UVLO Hysteresis	$V_{HYS}$			120		mV
Output Voltage Accuracy	$\Delta V_{OUT}$	$V_{IN}=(V_{OUT(NOM)}+1V)$ to 6V $I_{OUT}=1mA$ to 500mA ( $V_{OUT}\geq 1.8V$ )	-2.5%		2.5%	$V_{OUT}$
		$V_{IN}=(V_{OUT(NOM)}+1V)$ to 6V $I_{OUT}=1mA$ to 500mA ( $V_{OUT}< 1.8V$ )	-3%		3%	
Line Regulation	$\Delta V_{OUT}/\Delta V_{IN}$	$V_{IN}=(V_{OUT(NOM)}+1V)$ to 6V $I_{OUT}=1mA$		0.2		mV/V
Load Regulation	$\Delta V_{OUT}/\Delta I_{LOAD}$	$I_{OUT}=1mA$ to 500mA		0.04		mV/mA
Load Current	$I_{LOAD}$		0		500	mA
Quiescent Current	$I_Q$	$V_{EN}=1.2V$ , $I_{OUT}=0mA$		11	25	$\mu A$
Ground Current	$I_{GND}$	$V_{EN}=1.2V$ , $I_{OUT}=0mA$		12	25	$\mu A$
		$V_{EN}=1.2V$ , $I_{OUT}=500mA$		200	360	$\mu A$
		$V_{EN}=0.3V$		0.2	1	$\mu A$
Dropout Voltage	$V_{DO}$	$I_{OUT}=100mA$		50	100	mV
		$I_{OUT}=500mA$		280	500	
Output Current Limit	$I_{LIM}$	$2.2V \leq V_{IN} \leq 6V$	505	800		mA
Short-Circuit Current Limit	$I_{SC}$	$T_A=25^{\circ}C$		180		mA
Power-Supply Rejection Ratio <sup>6)</sup>	PSRR	$f=100Hz$ , $I_{OUT}=20mA$		90		dB
		$f=1kHz$ , $I_{OUT}=20mA$		82		
		$f=10kHz$ , $I_{OUT}=20mA$		65		
		$f=100kHz$ , $I_{OUT}=20mA$		60		
		$f=1MHz$ , $I_{OUT}=20mA$		40		
Output Noise Voltage <sup>6)</sup>	$V_{NO}$	BW= 10Hz to 100kHz	$I_{OUT}=1mA$		14	$\mu V_{RMS}$
			$I_{OUT}=500mA$		12	
Output Discharge Resistance	$R_{PD}$	$V_{EN}=0V$ (Disabled)		300		$\Omega$
EN Pin High-Level Input Voltage(Enable Device)	$V_{ENH}$		1.2			V
EN Pin Low-Level Input Voltage(Disable Device)	$V_{ENL}$				0.35	V

$V_{IN}=V_{OUT(NOM)}+1V$ ,  $V_{EN}=1.2V$ ,  $I_{OUT}=1mA$ ,  $C_{IN}=1\mu F$ ,  $C_{OUT}=1\mu F$ ,  $T_J=-40^{\circ}C$  to  $125^{\circ}C$ , unless otherwise stated.

ITEM	SYMBOL	CONDITIONS	MIN.	TYP.	MAX.	UNIT
EN Leakage Current	I <sub>EN_LKG</sub>	V <sub>EN</sub> =6V, V <sub>IN</sub> =6V		1	1.5	μA
		V <sub>EN</sub> =0V, V <sub>IN</sub> =6V		0.001		
Turn On Time	t <sub>ON</sub>	V <sub>EN</sub> >V <sub>ENH</sub> to V <sub>OUT</sub> =95% of V <sub>OUT(NOM)</sub> , V <sub>OUT</sub> =3.3V		700		μs
Thermal Shutdown <sup>6)</sup>	T <sub>TSD</sub>			160		°C
Thermal Shutdown Hysteresis <sup>6)</sup>	T <sub>TSD_HYST</sub>			15		°C

**Note:**

6) Guaranteed by design.

JoulWatt Confidential

**PIN DESCRIPTION**

PIN			NAME	DESCRIPTION
EWDFN2*2-6	X2DFN1*1-4	SOT23-5		
1	1	5	OUT	Output of the regulator. A 1 $\mu$ F or larger output capacitor is recommended.
2	-	4	NC	Not connected.
3	2	2	GND	Ground.
4	3	3	EN	Enable input.
5	-	-	NC	Not connected.
6	4	1	IN	Supply voltage input. A 1 $\mu$ F or larger input capacitor is recommended.
Exposed Pad	-	-	-	The exposed pad should be connected to a large ground plane to maximize thermal performance.

**BLOCK DIAGRAM**

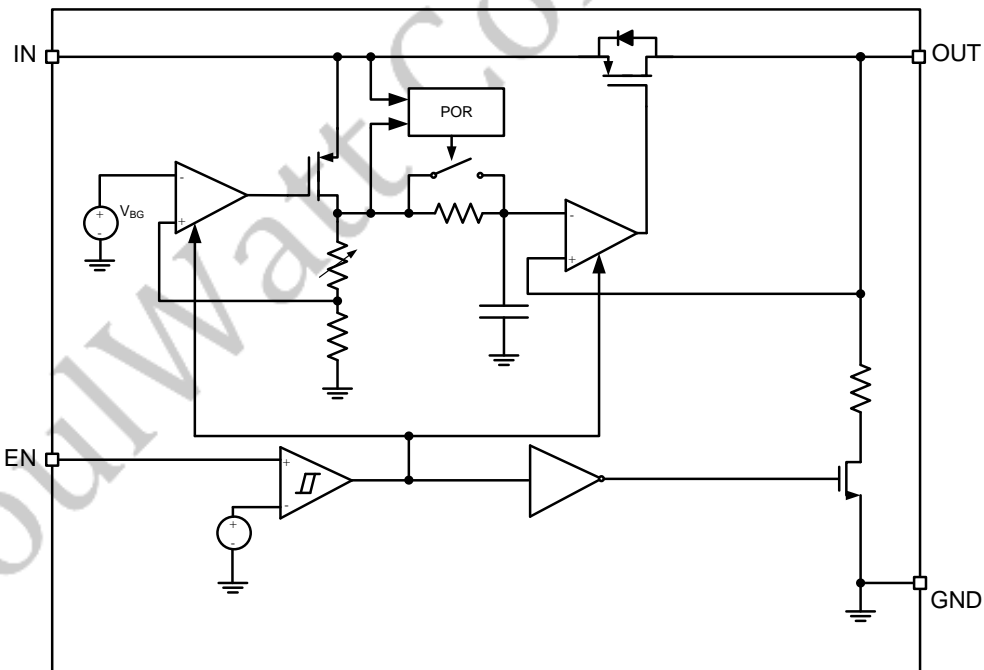

### TYPICAL PERFORMANCE CHARACTERISTICS

$V_{IN} = V_{OUT(NOM)} + 1V$  (whichever is greater),  $V_{OUT(NOM)} = 3.3V$ ,  $V_{EN} = 1.2V$ ,  $C_{IN} = 1\mu F$ ,  $C_{OUT} = 1\mu F$ ,  $I_{OUT} = 1mA$ , and  $T_A = 25^\circ C$ , unless otherwise noted.

**Start-Up**

$V_{IN} = 5.5V, V_{OUT} = 3.3V, I_{OUT} = 1mA$

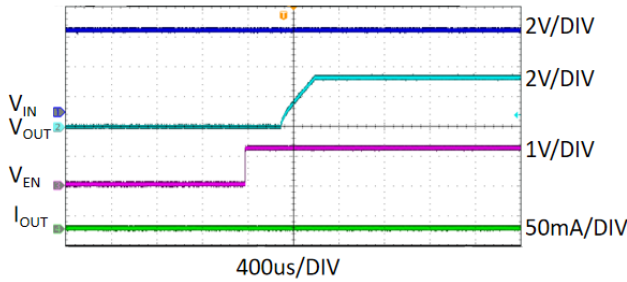

**Start-Up**

$V_{IN} = 5.5V, V_{OUT} = 3.3V, I_{OUT} = 500mA$

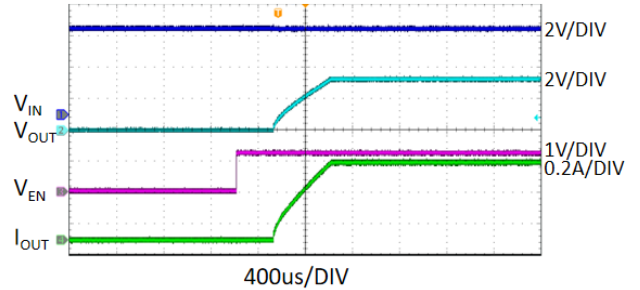

**Short Circuit Protection**

$V_{IN} = 4.3V, V_{OUT} = 3.3V, I_{OUT} = 0A$  to short

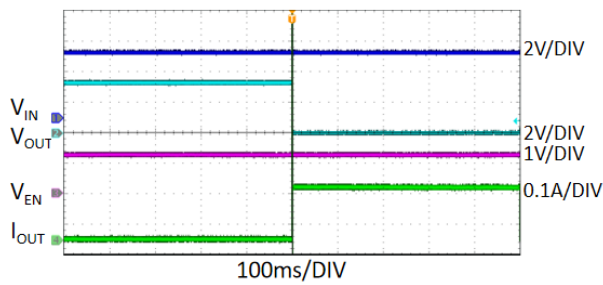

**Short Circuit Protection**

$V_{IN} = 5.5V, V_{OUT} = 3.3V, I_{OUT} = 0A$  to short

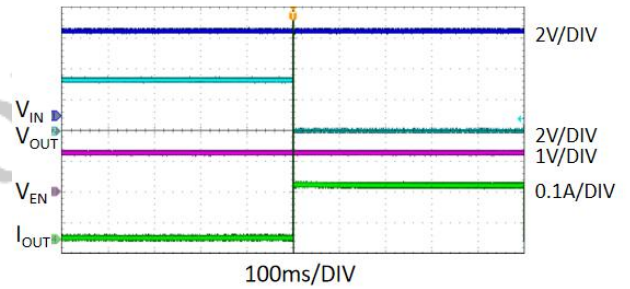

**Short Circuit Recovery**

$V_{IN} = 4.3V, V_{OUT} = 3.3V$

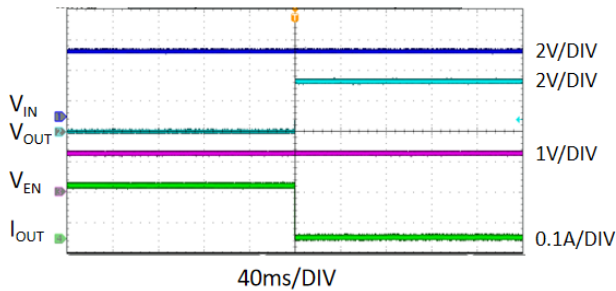

**Short Circuit Recovery**

$V_{IN} = 5.5V, V_{OUT} = 3.3V$

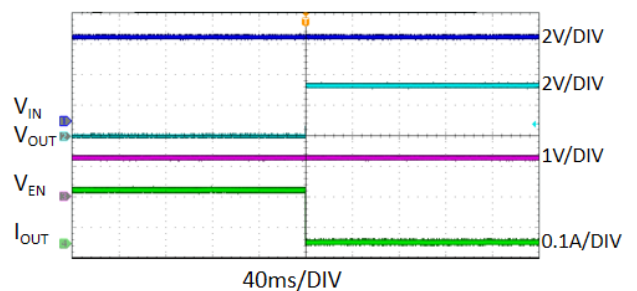

Output Spectral Noise Density vs Frequency

$V_{IN} = 2.2V, V_{OUT} = 1.2V$

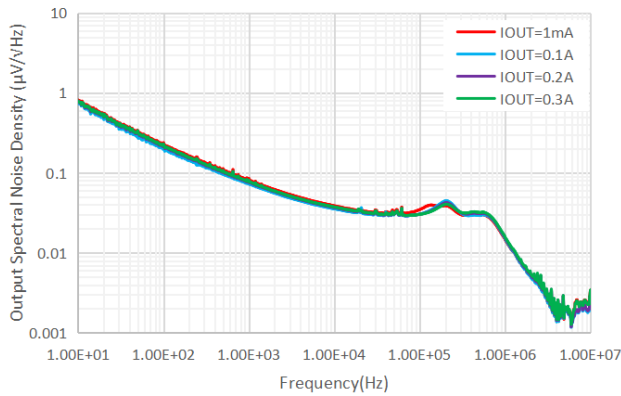

Output Spectral Noise Density vs Frequency

$V_{IN} = 2.8V, V_{OUT} = 1.8V$

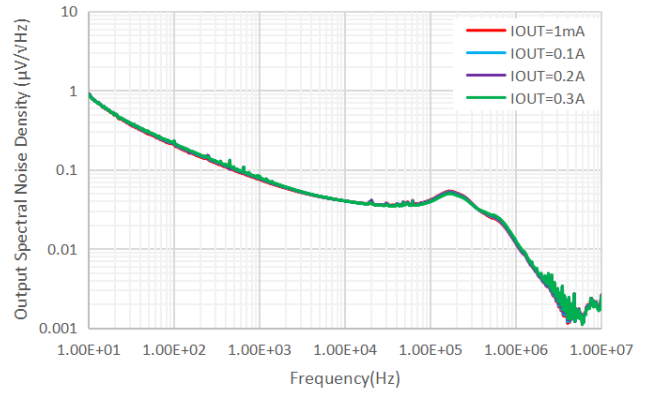

Output Spectral Noise Density vs Frequency

$V_{IN} = 3.8V, V_{OUT} = 2.8V$

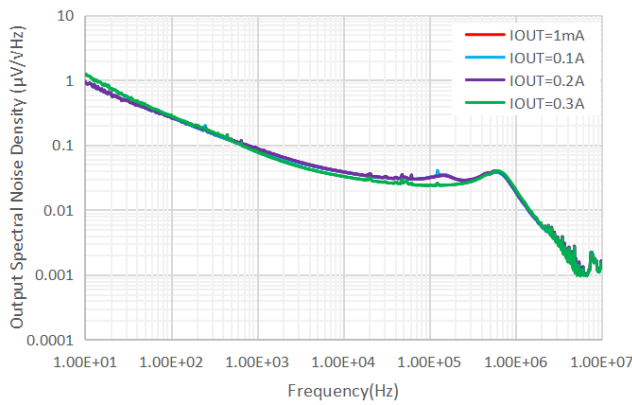

Output Spectral Noise Density vs Frequency

$V_{IN} = 4.3V, V_{OUT} = 3.3V$

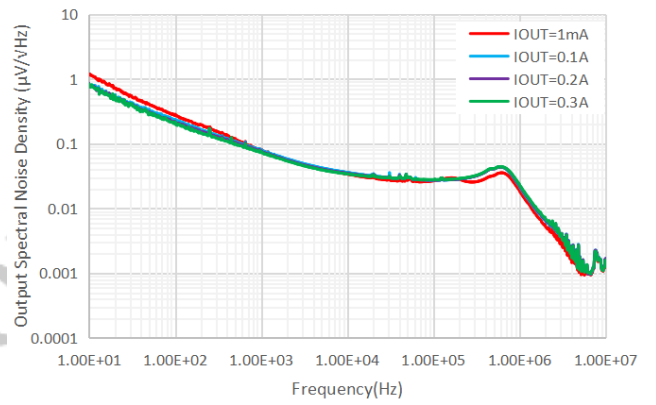

Output Spectral Noise Density vs Frequency

$V_{IN} = V_{OUT} + 1V, I_{OUT} = 1mA$

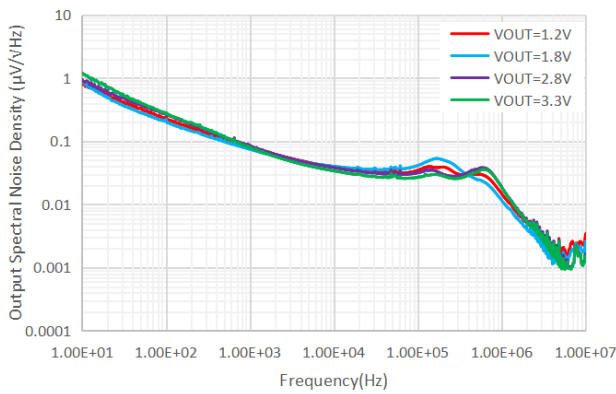

Output Spectral Noise Density vs Frequency

$V_{IN} = V_{OUT} + 1V, I_{OUT} = 300mA$

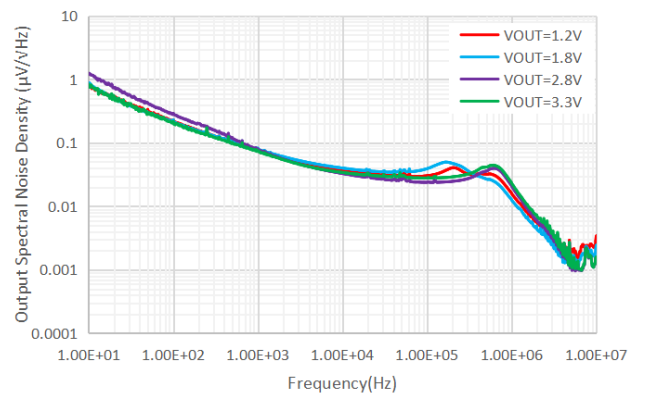

**PSRR vs Frequency**

$V_{OUT}=1.2V, C_{IN}=NC, C_{OUT}=1\mu F$

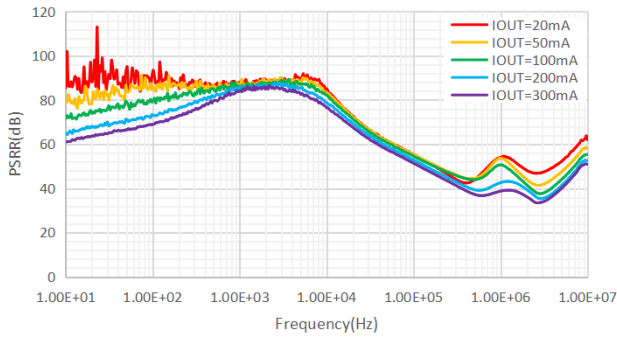

**PSRR vs Frequency**

$V_{OUT}=1.8V, C_{IN}=NC, C_{OUT}=1\mu F$

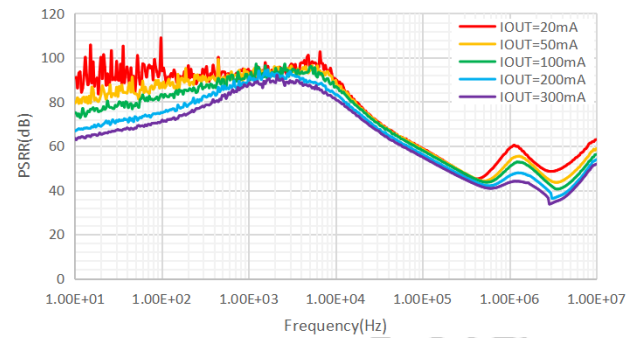

**PSRR vs Frequency**

$V_{OUT}=2.8V, C_{IN}=NC, C_{OUT}=1\mu F$

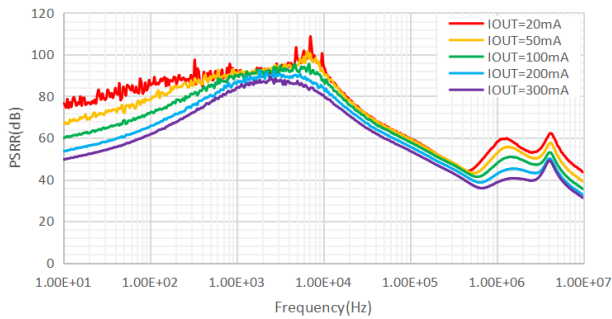

**PSRR vs Frequency**

$V_{OUT}=3.3V, C_{IN}=NC, C_{OUT}=1\mu F$

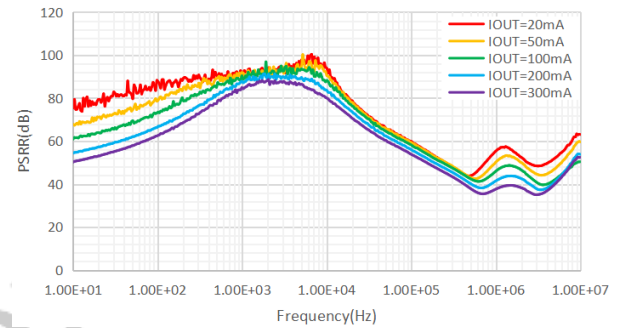

**Quiescent vs Input Voltage**

$V_{EN}=1.2V$

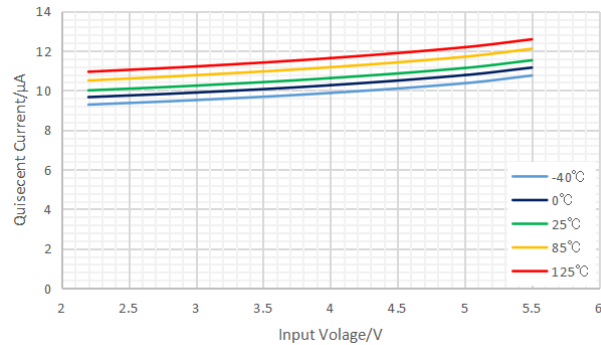

**Ground vs Input Voltage**

$V_{EN}=0.3V$

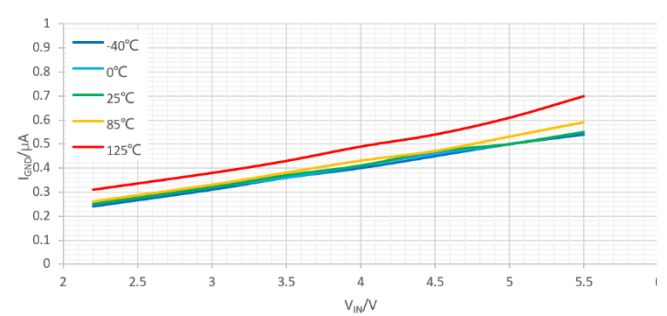

Ground Current vs Load Current

$V_{IN}=4.3V, V_{EN}=1.2V$

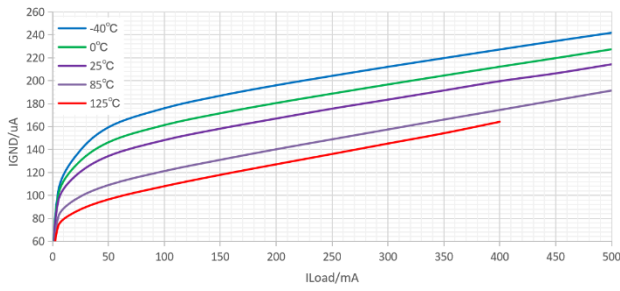

Dropout Voltage vs Load Current

$V_{IN}=3.3V, V_{EN}=1.2V$

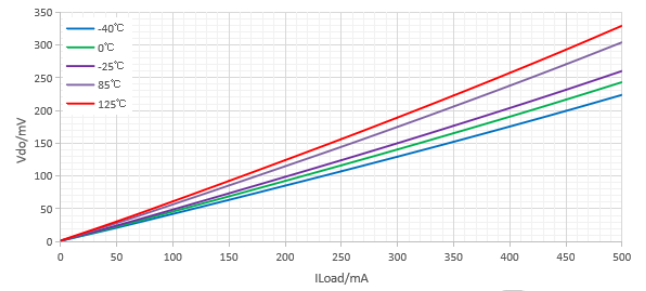

JoulWatt Confidential

## FUNCTIONAL DESCRIPTION

The JW7809 is a low noise, low quiescent current linear regulator. The input voltage range is from 2.2V to 6V, and the output current is up to 500mA. The minimum required output capacitance for stable operation is 1 $\mu$ F effective capacitance after consideration of the temperature and voltage coefficient of the capacitor.

### Output Transistor

The JW7809 builds in a P-MOSFET transistor which provides a low switch-on resistance for low dropout voltage applications.

### Error Amplifier

The Error Amplifier (EA) compares the internal reference voltage  $V_{REF}$  with the output feedback voltage  $V_{FB}$  through the internal divider. Output of the error amplifier (EA) is used to control the gate voltage of P-MOSFET and ensures that the device provides good line and load regulation at output voltage.

### Enable

The device is active when EN pin is set to high. For proper operation, this pin must be terminated and must not be left floating. With EN pin set to low, the device enters shutdown mode with less than 1 $\mu$ A current consumption.

### Current Limit Protection

JW7809 provides current limit function to prevent the device from damages during the over load or shorted-circuit condition. The current is detected by a sensing transistor, which monitors and controls the pass transistor's gate voltage, limiting the output current to 800mA (TYP.). The PMOS

pass transistor dissipates  $(V_{IN} - V_{OUT}) * I_{LIM}$  until thermal shutdown is triggered and the device turns off. When the device cools, the internal thermal shutdown circuit turns the device back on. If the fault condition continues, the device cycles between current limit and thermal shutdown. Current limit will fold back to 180mA when out is short to GND. The pass transistor conducts current when output voltage exceeds input voltage due to built-in body diode. External protect circuit should be added if the device may work at reverse voltage state.

### Output Discharge

The device provides automatic output voltage discharge once it is disabled. This feature prevents residual charge voltage on the output capacitor, which may impact proper power up of the system connected to the converter. The discharge circuit at  $V_{OUT}$  pin becomes active once the EN pin is pulled to low or the input voltage drops below UVLO comparator threshold.

### Low Output Noise

Any internal noise at the JW7809 reference voltage is reduced by a first order low-pass RC filter before it is passed to the output buffer stage. The low-pass RC filter has a -3dB cut-off frequency of approximate 0.1Hz.

### Thermal Protection

When the temperature of the JW7809 rises above 160°C, it is forced into thermal shutdown. Only when core temperature drops below 145°C can the device become active again.

## APPLICATION INFORMATION

### CIN and COUT Selection

The JW7809 is designed to support low ESR (Equivalent Series Resistance) ceramic capacitors. It is recommended to use ceramic capacitors (dielectric types X5R, X7R or COG) to obtain good stability across different temperatures. A better choice for temperature coefficient in a ceramic capacitor is X7R. This type of capacitor is the most stable and holds the capacitance within  $\pm 15\%$  over the temperature range.

A typically  $1\mu\text{F}$  or greater output ceramic capacitor is suggested. The output capacitor must meet the requirement for the minimum value of capacitance and have an ESR value that is within the range  $5\text{m}\Omega$  to  $100\text{m}\Omega$  for stability. The initial tolerance, applied voltage de-rating, and temperature coefficient must all be considered when selecting the output capacitor to ensure the actual capacitance is never less than  $1\mu\text{F}$  over the entire operating range.

Input capacitance is selected to minimize transient input drop during load current steps. For general applications, an input capacitor, typically  $1\mu\text{F}$ , is highly recommended to minimize input impedance. If the trace parasitic inductance between the JW7809 input pin and power supply is high, a fast load transient can cause input voltage level ringing above the absolute maximum voltage rating which damages the device. Adding more input capacitors is available to restrict the ringing and keep it below the device absolute maximum ratings. Like the output capacitor, the initial tolerance, applied voltage de-rating, and temperature coefficient must all be considered when selecting the input capacitor to ensure the actual capacitance is never less than  $1\mu\text{F}$  over the entire operating range.

### Dropout Voltage

The JW7809 uses a PMOS to achieve low dropout. When  $(V_{\text{IN}} - V_{\text{OUT}})$  is less than the dropout voltage ( $V_{\text{DO}}$ ), the PMOS pass device is in its linear region of operation and the input-to-output resistance is the  $R_{\text{DS(ON)}}$  of the PMOS.  $V_{\text{DO}}$  scales approximately with output current because the PMOS device in dropout behaves the same way as a resistor.

### Power Dissipation and Device Operation

The permissible power dissipation for any package depends on the capability of the device passing heat from the power source, the junctions of the IC, to the ultimate heat sink, the ambient environment.

The maximum permissible power dissipation for the device in a given package can be calculated using Equation 1:

$$P_{D-\text{MAX}} = (T_{J-\text{MAX}} - T_A) / R_{\theta JA}$$

Where the  $T_{J-\text{MAX}} = 125^\circ\text{C}$

Power dissipation in the regulator depends on the input-to-output voltage difference and load conditions.  $P_D$  can be calculated by the following equation.

$$P_D = (V_{\text{IN}} - V_{\text{OUT}}) \times I_{\text{OUT}}$$

The maximum power dissipation determines the maximum allowable junction temperature ( $T_J$ ) for the device. Power dissipation and junction temperature are most often related by the junction-to-ambient thermal resistance ( $R_{\theta JA}$ ) of the combined PCB and device package and the temperature of the ambient air ( $T_A$ ), according to

$$T_J = T_A + (\theta_{JA} \times P_D)$$

**Layout Guidelines**

Place all circuit components on the same side of the circuit board and as close to the respective LDO pin as possible. Place ground return connections to the input and output capacitor.

Connect the ground plane with a wide copper surface for good thermal dissipation. Using vias and long power traces for the input and output capacitors connections is not recommended and negatively effects system performance.

EWDNF2\*2-6:

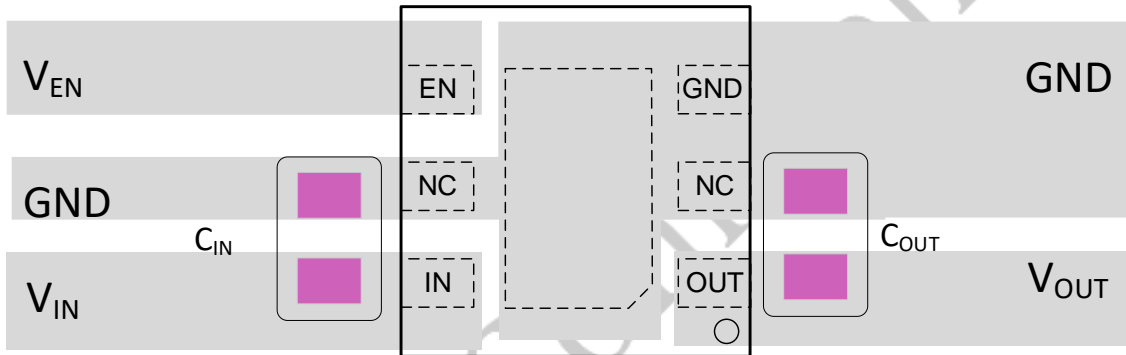

SOT23-5:

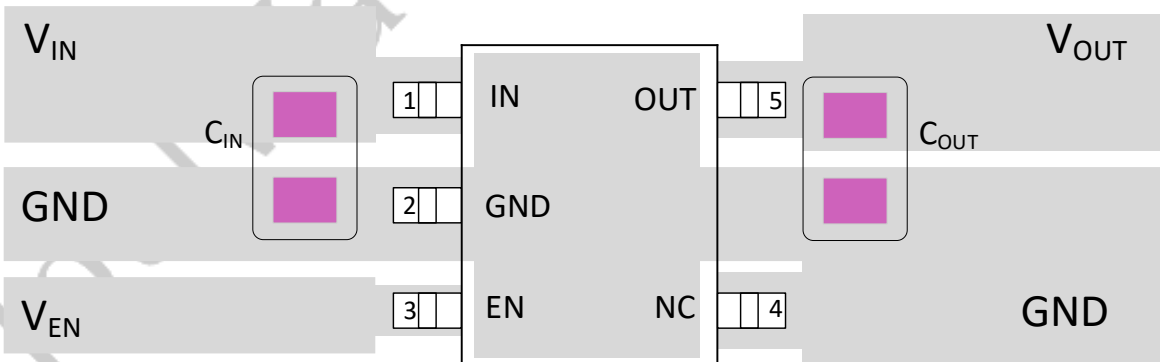

X2DFN1\*1-4:

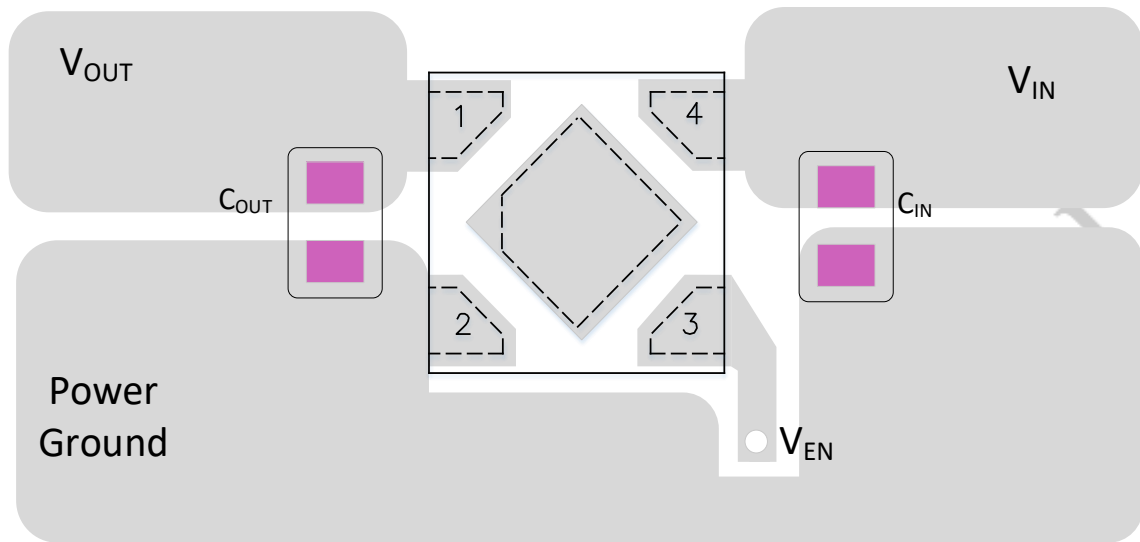

PCB Layout Recommendation

JoulWatt Confidential

TAPE AND REEL INFORMATION

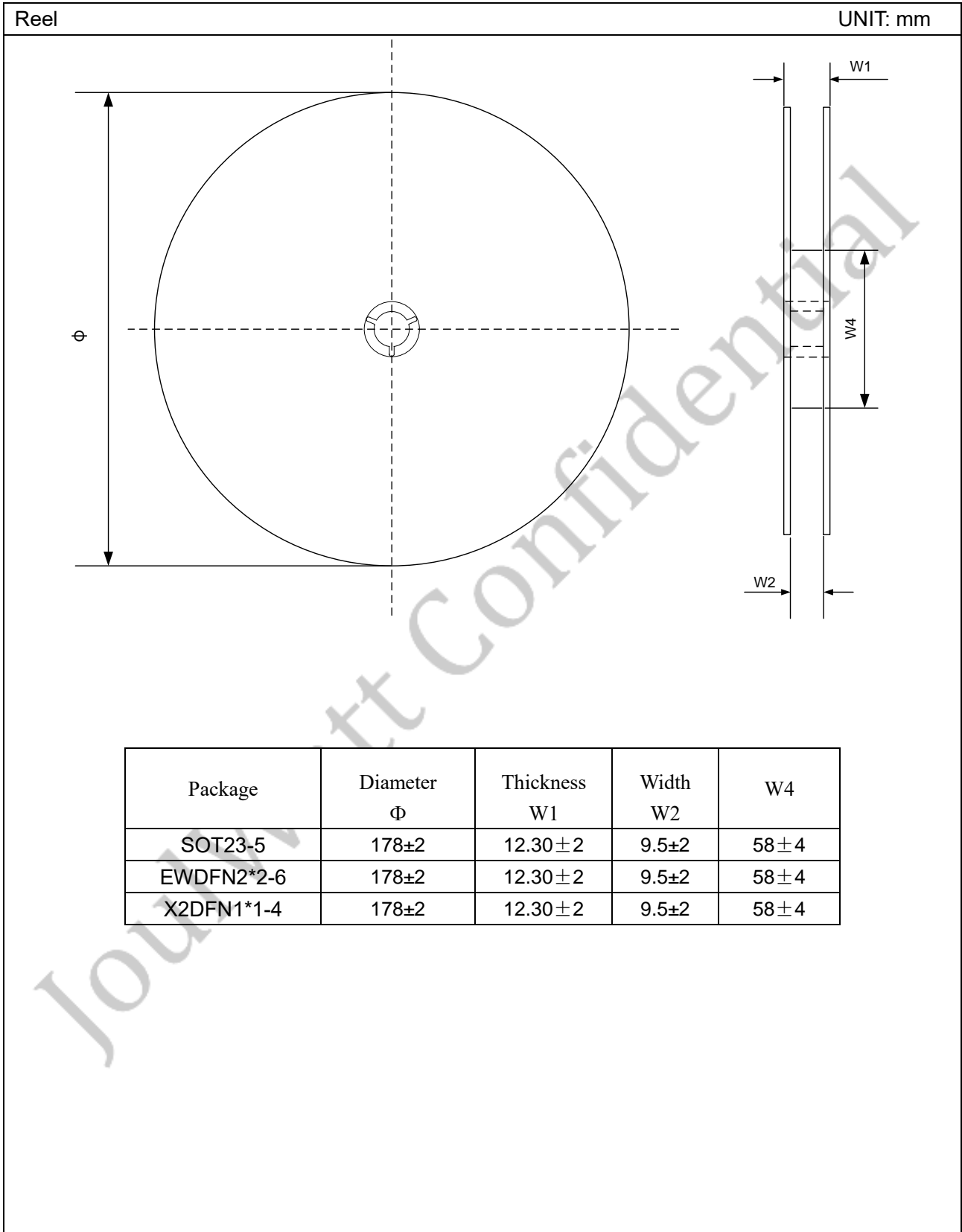

Carrier Tape

UNIT: mm

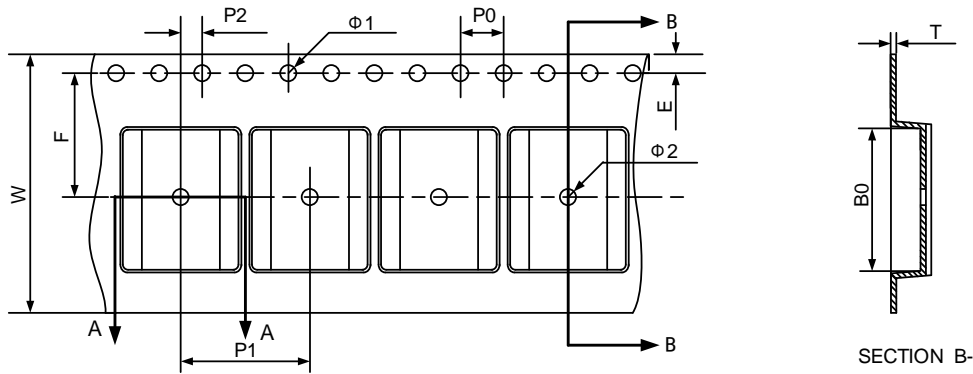

SECTION A-A

Note :

- 1) The carrier type is black, and colorless transparent.
- 2) Carrier camber is within 1mm in 100mm.
- 3) 10 pocket hole pitch cumulative tolerance:±0.20.
- 4) All dimensions are in mm.

Package	Tape dimensions (mm)											
	P0	P2	P1	A0	B0	W	T	K0	Φ1	Φ2	E	F
SOT23-5	4.0±0.1	2.0±0.1	4.0±0.1	3.23±0.2	3.13±0.3	8.0±0.3	0.25±0.2	1.37±0.2	1.55±0.15	1.00min	1.75±0.1	3.50±0.1
EWDFN2*2-6	4.0±0.1	2.0±0.1	4.0±0.1	2.3±0.2	2.3±0.2	8.0±0.3	0.25±0.2	1.1±0.35	1.50min	1.00min	1.75±0.1	3.50±0.1
X2DFN1*1-4	4.0±0.1	2.0±0.1	2.0±0.1	1.16±0.1	1.16±0.1	8.0±0.3	0.2±0.1	0.5±0.1	1.5±0.1	0.5±0.1	1.75±0.1	3.50±0.1

PACKAGE OUTLINE

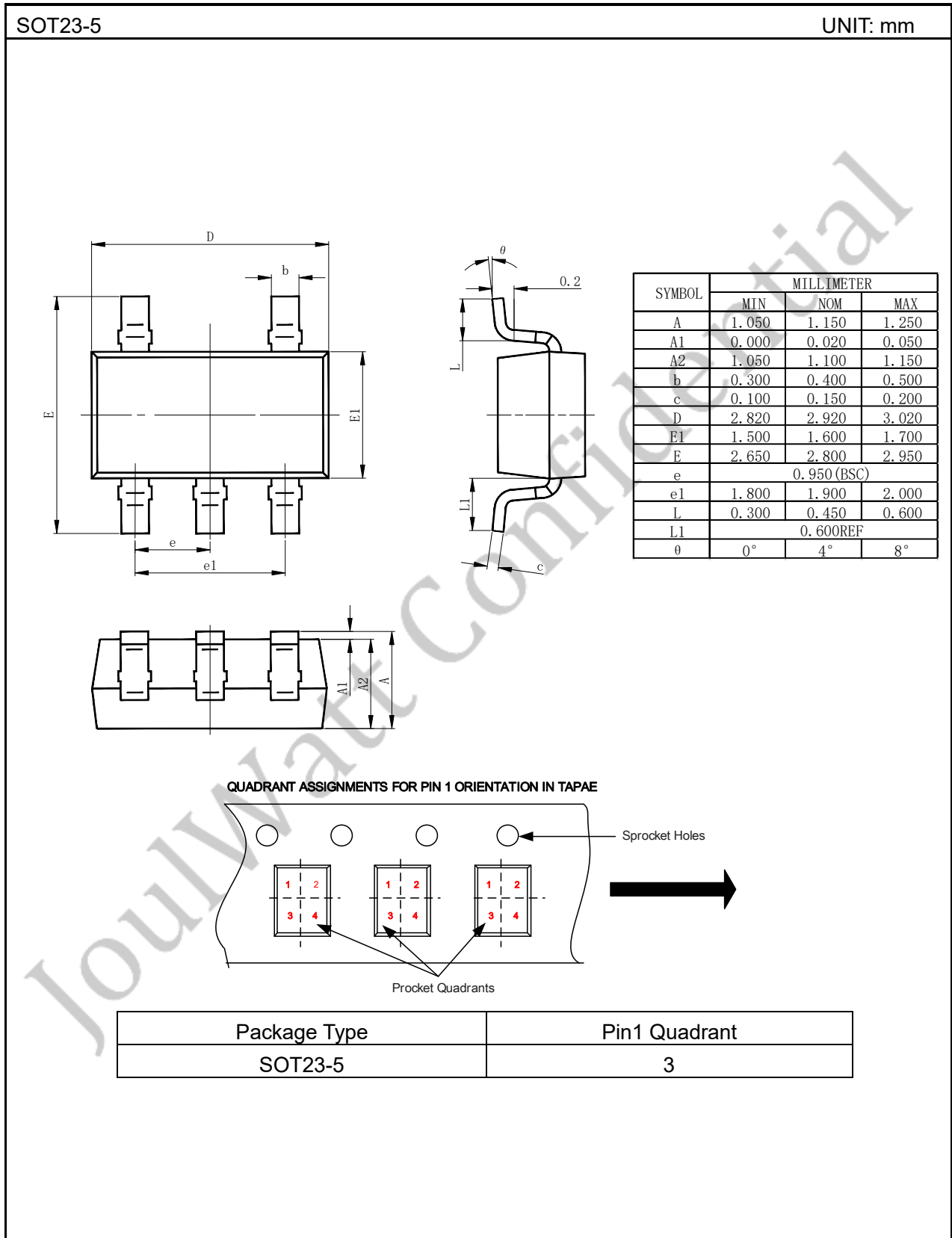

X2DFN1\*1-4

UNIT: mm

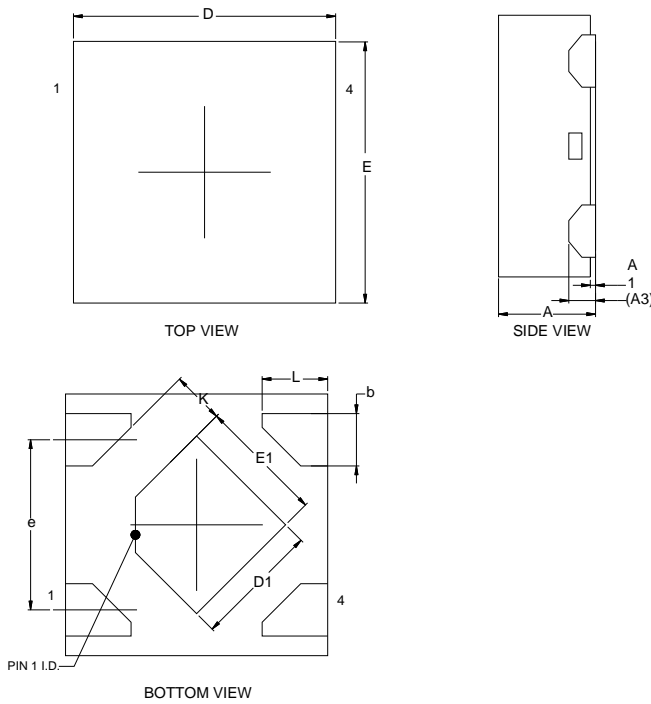

SYMBOL	MILLIMETER		
	MIN	NOM	MAX
A	0.32	0.37	0.40
A1	0.00	0.02	0.05
A3	0.102 REF		
b	0.15	0.20	0.25
D	0.90	1.00	1.10
E	0.90	1.00	1.10
e	0.65 BSC		
D1	0.38	0.48	0.58
E1	0.38	0.48	0.58
L	0.15	0.25	0.35
K	0.200 REF		

QUADRANT ASSIGNMENTS FOR PIN 1 ORIENTATION IN TAPAE

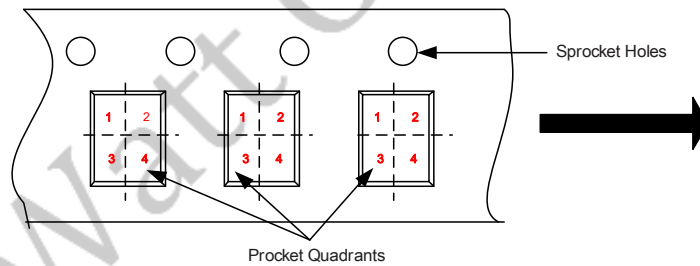

Package Type	Pin1 Quadrant
X2DFN1*1-4	1

EWDFN2\*2-6

UNIT: mm

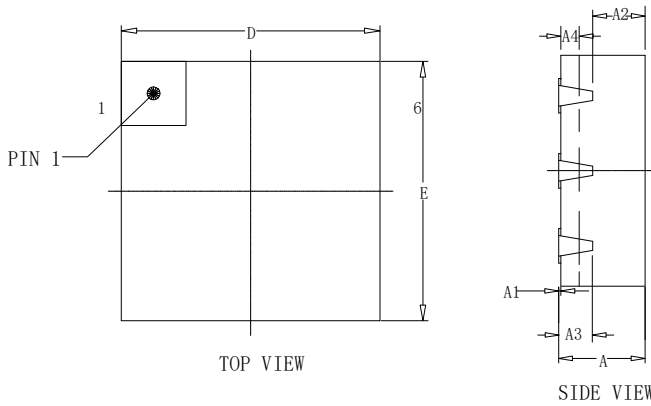

SYMBOL	MILLIMETER		
	MIN	NOM	MAX
A	0.70	0.75	0.80
A1	0.00	0.02	0.05
A2	---	0.55	---
A3	0.203 REF		
A4	0.075	---	0.18
b	0.25	0.30	0.35
D	1.90	2.00	2.10
E	1.90	2.00	2.10
D1	0.90	1.00	1.10
E1	1.50	1.60	1.70
e	0.65 BSC		
L	0.20	0.25	0.30
L1	0.01	---	0.09

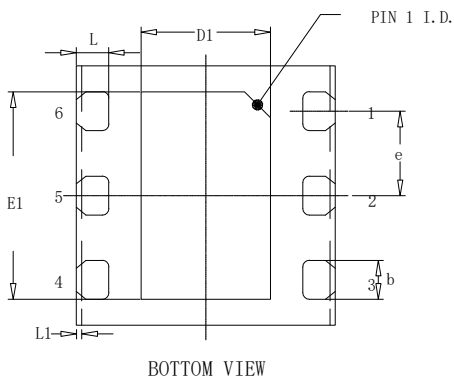

QUADRANT ASSIGNMENTS FOR PIN 1 ORIENTATION IN TAPAE

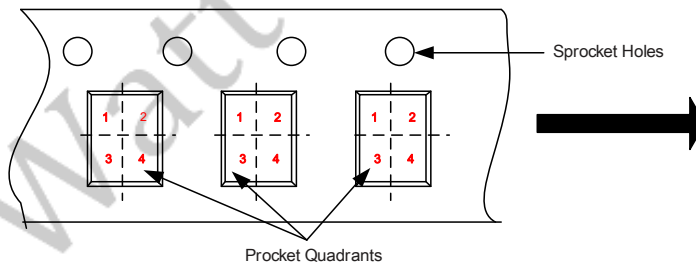

Package Type	Pin1 Quadrant
EWDFN2*2-6	2

**IMPORTANT NOTICE**

- Joulwatt Technology Co.,Ltd reserves the right to make modifications, enhancements, improvements, corrections or other changes without further notice to this document and any product described herein.
- Any unauthorized redistribution or copy of this document for any purpose is strictly forbidden.
- Joulwatt Technology Co.,Ltd does not warrant or accept any liability whatsoever in respect of any products purchased through unauthorized sales channel.
- JOULWATT TECHNOLOGY CO.,LTD PROVIDES TECHNICAL AND RELIABILITY DATA (INCLUDING DATASHEETS), DESIGN RESOURCES (INCLUDING REFERENCE DESIGNS), APPLICATION OR OTHER DESIGN ADVICE, SAFETY INFORMATION AND OTHER RESOURCES, AND DISCLAIMS ALL WARRANTIES, EXPRESS AND IMPLIED, INCLUDING WITHOUT LIMITATION ANY IMPLIED WARRANTIES OF MERCHANTABILITY, FITNESS FOR A PARTICULAR PURPOSE OR NON-INFRINGEMENT OF THIRD PARTY INTELLECTUAL PROPERTY RIGHTS.

*Copyright © 2024 JoulWatt*

*All rights are reserved by Joulwatt Technology Co.,Ltd*