

5		6		7		8	
REV.	DATE	ECN NO.	MODIFICATION		APPROVER		
A0	2020.06.30	/	NEW		Abel		

Specifications:
 Material:
 1.Housing: *Thermoplastic* Natural ,UL94V-0
 2.Contact: Brass,Sn plated over Nickel
 3.Solder: Brass,Sn plated over Nickel
 Electrical:
 1. Current Rating:2A AC
 2. Voltage Rating: 200V
 3.Contact Resistance: 20mΩ Max
 4.Dielectric Withstanding Voltage: 500V AC
 5.Insulation Resistance: 1000MΩ Min
 Environment characteristics:
 1.Operating Temperature: -40°C~+85°C
 Lead free and ROHS compliant product.

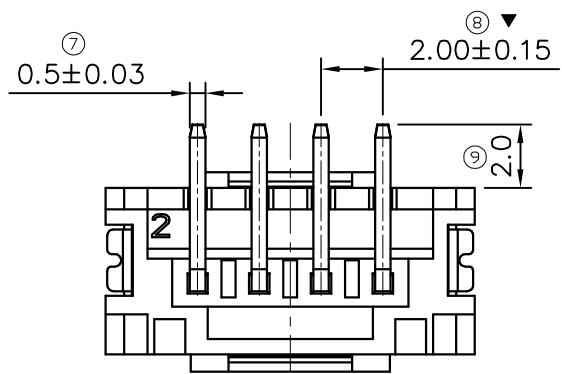
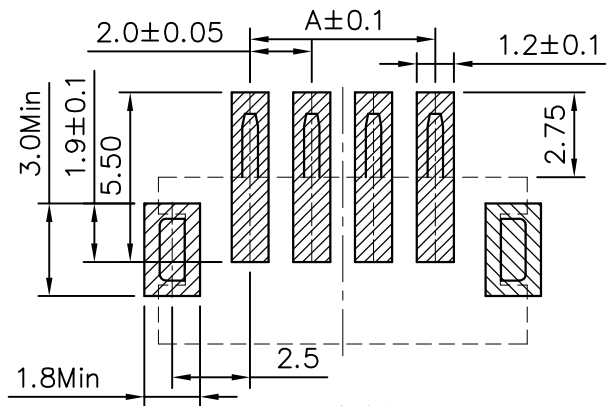
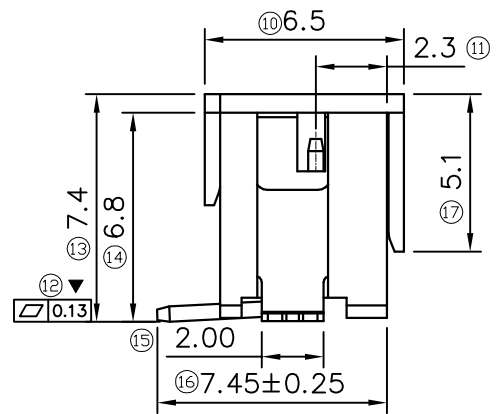
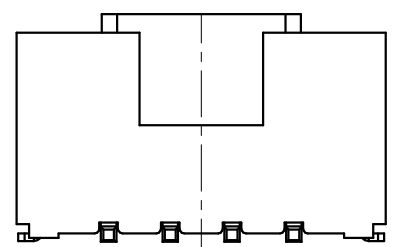
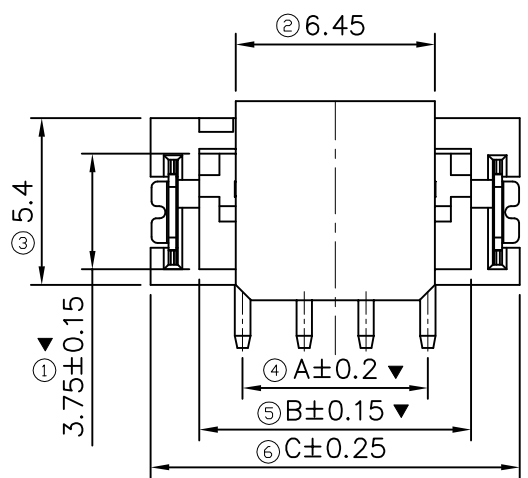

CKT	DIM A	DIM B	DIM C
2	2.00	4.80	7.95
3	4.00	6.80	9.95
4	6.00	8.80	11.95
5	8.00	10.80	13.95
6	10.00	12.80	15.95
7	12.00	14.80	17.95
8	14.00	16.80	19.95
9	16.00	18.80	21.95
10	18.00	20.80	23.95
11	20.00	22.80	25.95
12	22.00	24.80	27.95
13	24.00	26.80	29.95
14	26.00	28.80	31.95
15	28.00	30.80	33.95
16	30.00	32.80	35.95
17	32.00	34.80	37.95
18	34.00	36.80	39.95
19	36.00	38.80	41.95
20	38.00	40.80	43.95

适用线路板

GENERAL TOLERANCE			UNITS mm	NAME(INTENDED USE)	深圳市丰鼎力科技有限公司 Shenzhen Forward Co.Ltd.			
SELECT	✓			WF	TITLE: Customer Drawing For Wafer 2.0mm XP SMT 立贴 带夹持盖			
TOL.	1	2	MAT'L	PART NO.(INTENDED USE)	DWG NO.:			
X.XXX	±0.10	±0.15	FINISH	WF20***-02***	ATOM-A06741			
X.XX	±0.15	±0.20		APPD: Able	SCALE			
X.X	±0.20	±0.25	Q'TY	CHKD: Tom	SHEET			
X.	±0.25	±0.30		DR: Ling	REV.			
ANGLE	±2'			1:1			1/1	A0